



Parts Manual

Mfg. No: 030676-00
3,500 Watt Briggs & Stratton

Model Components	Page
Control Panel (80017979).....	4
Main Unit (80017978).....	6
Wheel Kit (80017980).....	10
Wiring Diagram (80017394WD).....	12
Wiring Schematic (80017394WS).....	14
Torque Specification Chart.....	16

Not For
Reproduction

Control Panel (80017979)

Note: Unless noted otherwise, use the standard torque specifications

Mfg. No: 030676-00

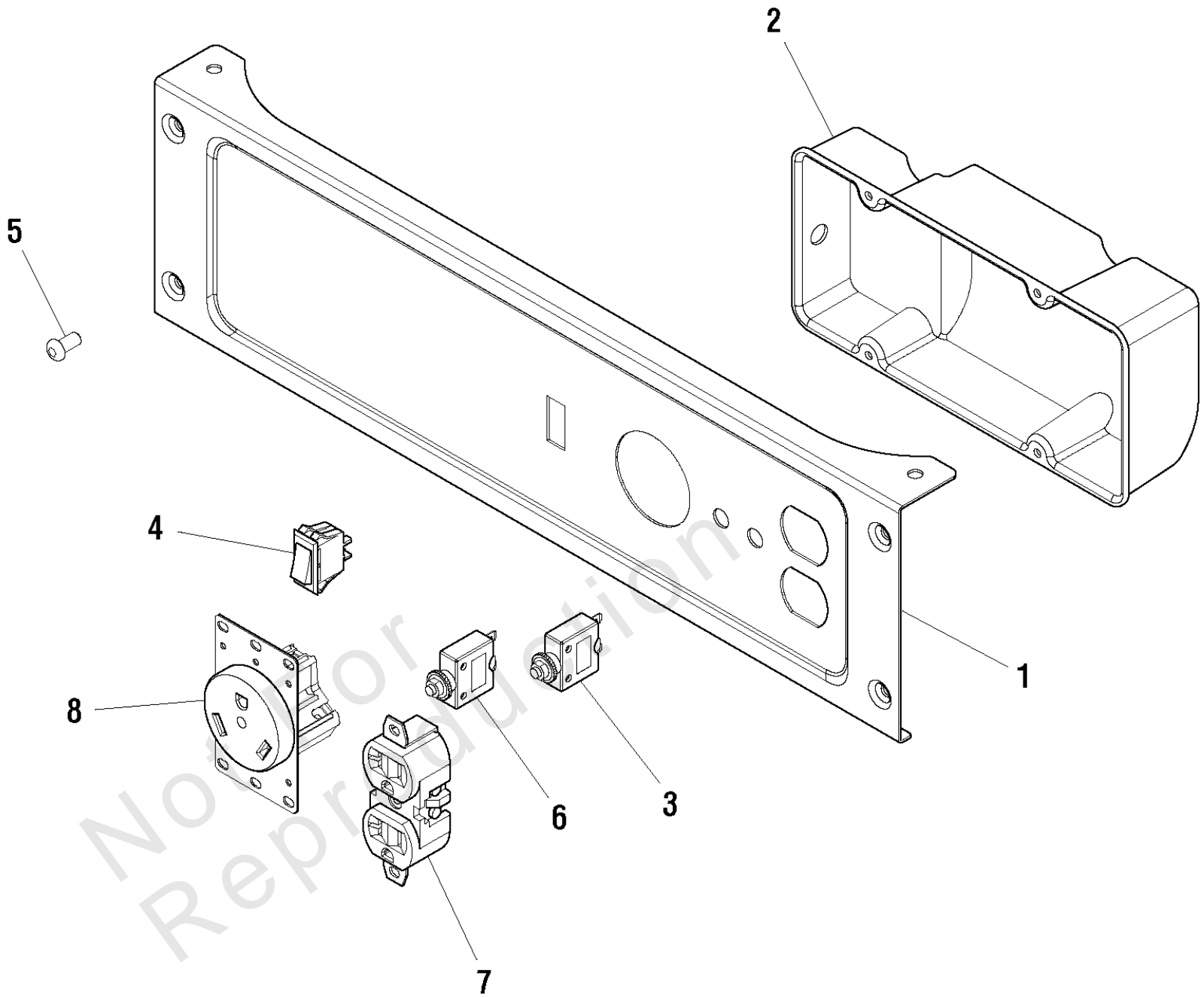

Control Panel (80017979)

REF NO	PART NO	QTY	DESCRIPTION
1	709672		PANEL-CONTROL
2	709673		BOX-CONTROL PANEL
3	318061GS		BREAKER-CIRCUIT 20A
4	319525GS		SWITCH-ON/OFF
5	703804		SCREW
6	318063GS		BREAKER-CIRCUIT 30A
7	208240GS		OUTLET
8	318065GS		OUTLET

Not For Reproduction

Main Unit (80017978)

Note: Unless noted otherwise, use the standard torque specifications

Mfg. No: 030676-00

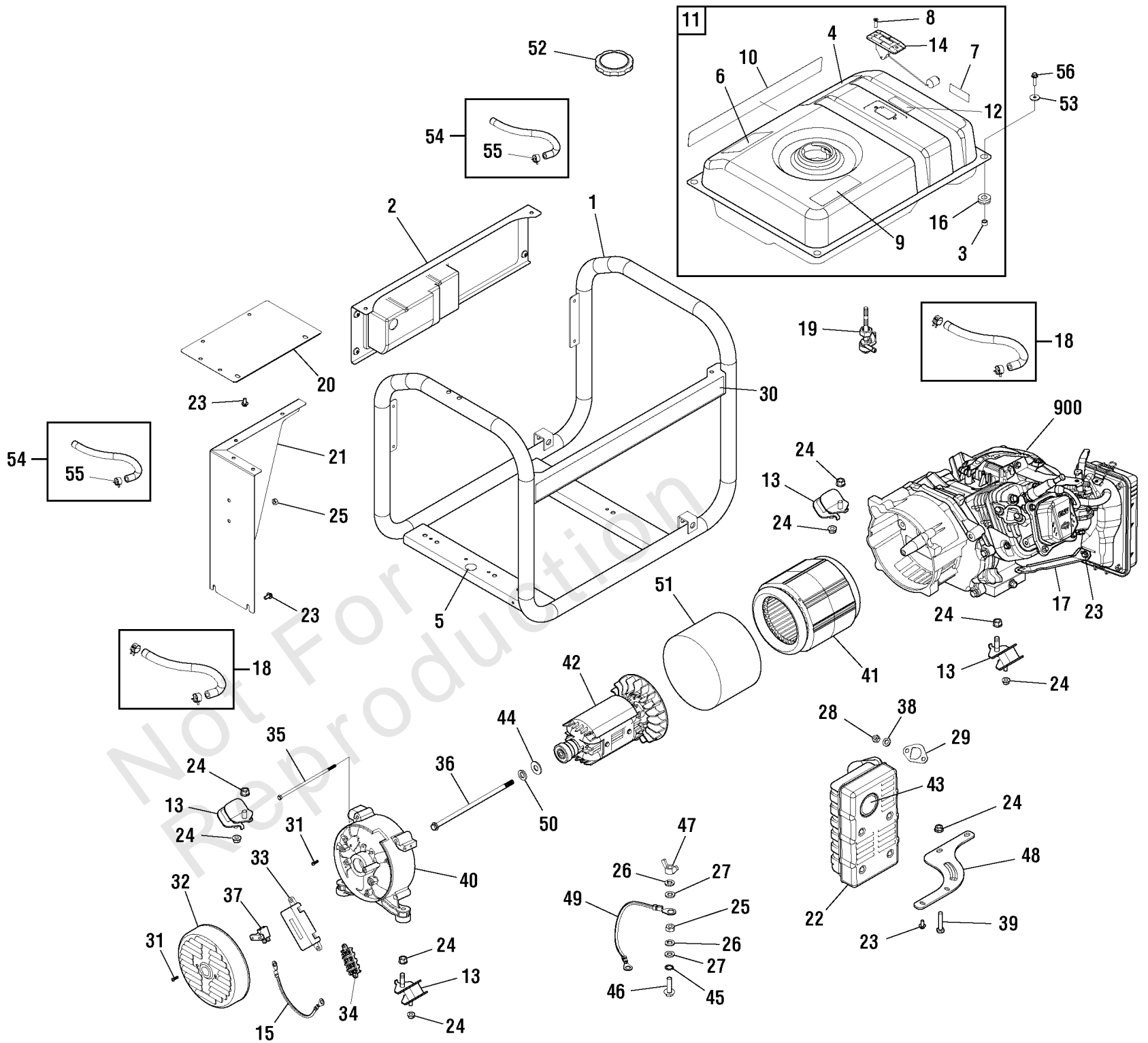

Main Unit (80017978)

REF NO	PART NO	QTY	DESCRIPTION
1	709654		CRADLE -(Includes Ref. Nos. 5 & 30)
2	709658		ASSY- PANEL CONTROL
3	189137GS		SPACER
4	709663		DECAL
5	704331		DECAL
6	202997GS		DECAL, Warning, CO
7	704142		DECAL
8	314440GS		SCREW
9	709667		DECAL
10	709659		DECAL
11	709656		TANK-FUEL
12	703264		DECAL
13	706149		MOUNT-VIBRATION
14	704183		GAUGE-FUEL
15	706150		WIRE
16	189134GS		GROMMET, Rubber
17	709662		BRACKET
18	791745		LINE, Fuel -(Cut to Fit)
19	209417GS		VALVE, Fuel
20	709655		HEATSHIELD
21	709660		HEATSHIELD
22	709665		MUFFLER
23	706152		SCREW, M6 x 12
24	-----		* NUT, Flange, M8
25	-----		* NUT, Hex, M6
26	-----		* WASHER, Lock, M6
27	-----		* WASHER, M6
28	45771GS		NUT, M8 - 1.25
29	709664		GASKET, Muffler Adapter
30	709669		DECAL
31	312909GS		SCREW
32	703191		COVER-REAR BEARING
33	709666		VOLTAGE REGULATOR
34	703075		TERMINAL BLOCK
35	703909		BOLT
36	313525GS		BOLT
37	703113		BRUSH ASSY
38	706162		LOCKWASTER, SPLIT, 3/8
39	-----		* BOLT, M8 x 40
40	703190		CARRIER-BEARING
41	709668		STATOR
42	709670		ROTOR
43	83083GS		SCREEN, Spark Arrest
44	189295GS		Washer, .432 x 1 x .064
45	26850GS		WASHER, Ext. M6 - 1/4" Shakeproof
46	189156GS		HHCS, M6-1.0 x 25

Footnotes:

(Note:* Verify your specific engine model, reference the ID Tag located on your engine.) (Refer to your local Briggs & Stratton distributor for parts and service.)
* Items without part numbers are common fasteners. Purchase locally.

Main Unit (80017978)

Note: Unless noted otherwise, use the standard torque specifications

Mfg. No: 030676-00

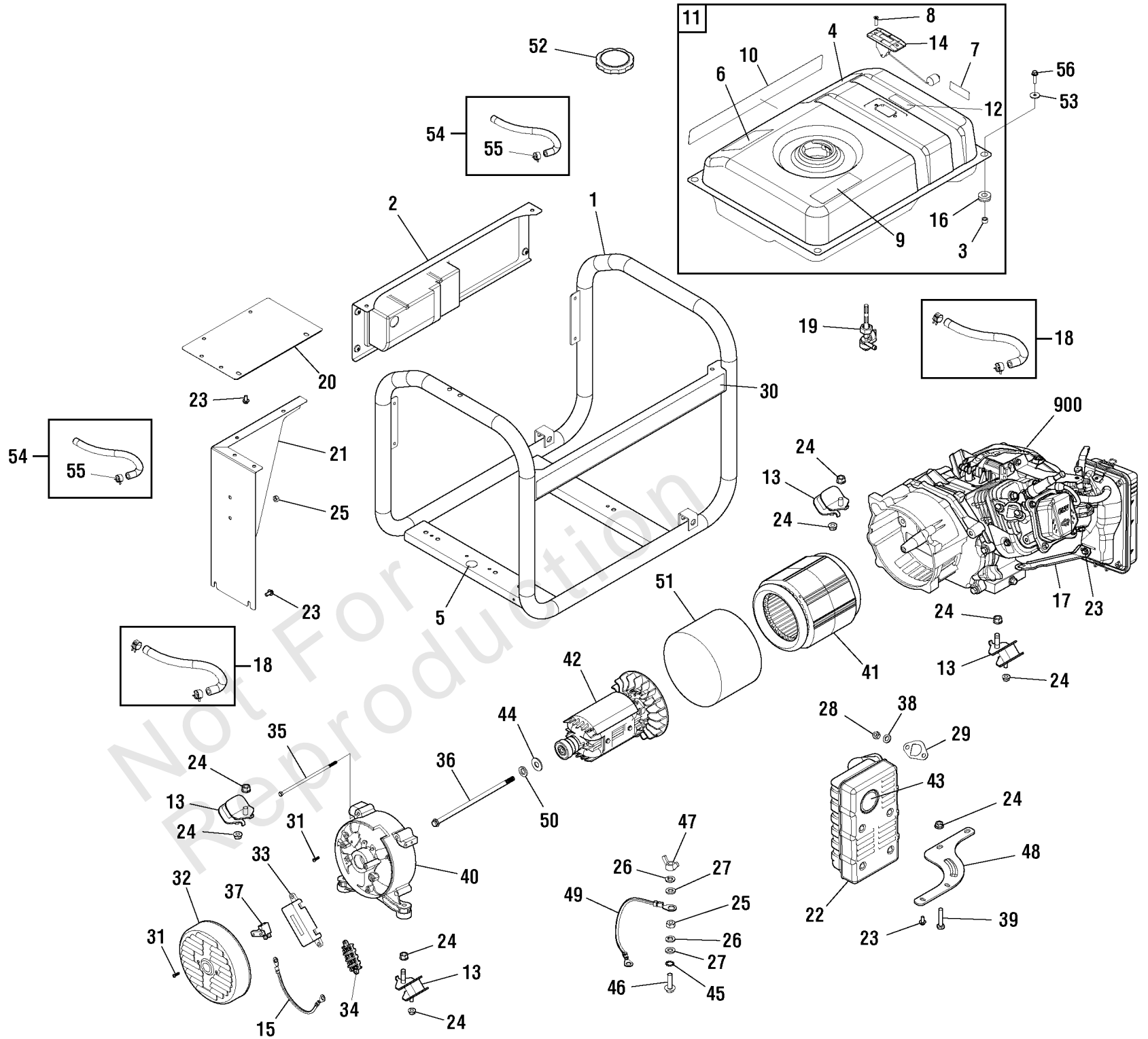

Main Unit (80017978)

REF NO	PART NO	QTY	DESCRIPTION
47	87680GS		NUT, M6 - 1.0 Wing
48	709661		BRACKET-MUFFLER
49	706165		WIRE
50	801237		WASHER
51	709657		BAND-STATOR
52	319587GS		CAP-FUEL
53	312005GS		WASHER
54	315017GS		HOSE, Vapor (cut to fit) -(Cut to Fit)
55	314955GS		CLAMP
56	703805		SCREW
900	13U132-0001-G1		ENGINE*

Not For
Reproduction

Footnotes:

(Note:* Verify your specific engine model, reference the ID Tag located on your engine.) (Refer to your local Briggs & Stratton distributor for parts and service.)

* Items without part numbers are common fasteners. Purchase locally.

Wheel Kit (80017980)

Note: Unless noted otherwise, use the standard torque specifications

Mfg. No: 030676-00

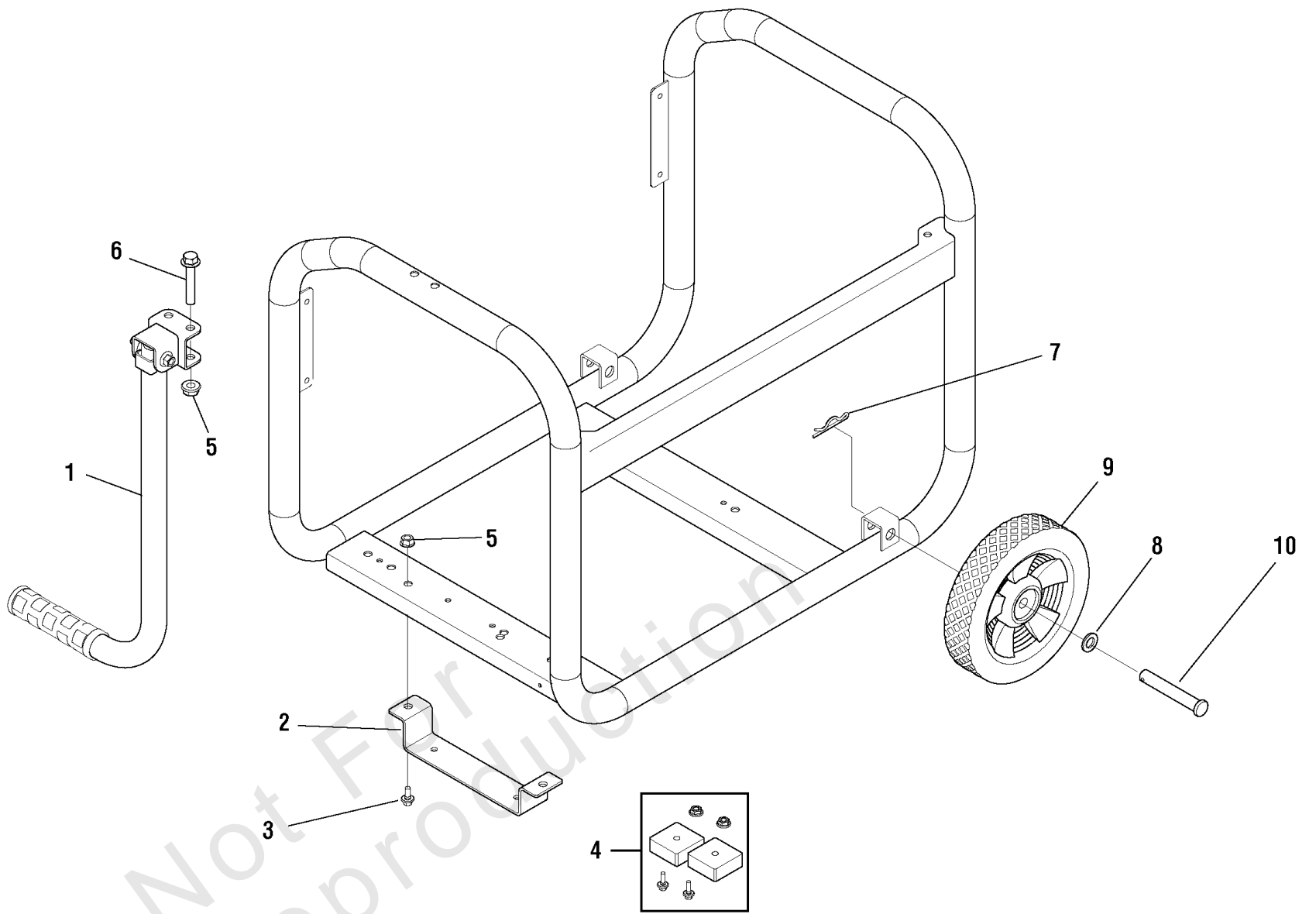

Wheel Kit (80017980)

REF NO	PART NO	QTY	DESCRIPTION
1	709676		HANDLE
2	709677		SUPPORT-LEG
3	-----		* BOLT, M8-1.25 x 16
4	319285GS		MOUNT-VIBRATION
5	-----		* NUT, Flange, M8
6	-----		* BOLT, M8 x 80
7	316510GS		PIN-HAIR
8	318034GS		WASHER
9	318032GS		WHEEL
10	318035GS		AXLE
--	707180		KIT-HARDWARE -(Not Illustrated)

Not For
Reproduction

Footnotes:

* Items without part numbers are common fasteners. Purchase locally.

Wiring Diagram (80017394WD)

Note: Unless noted otherwise, use the standard torque specifications

Mfg. No: 030676-00

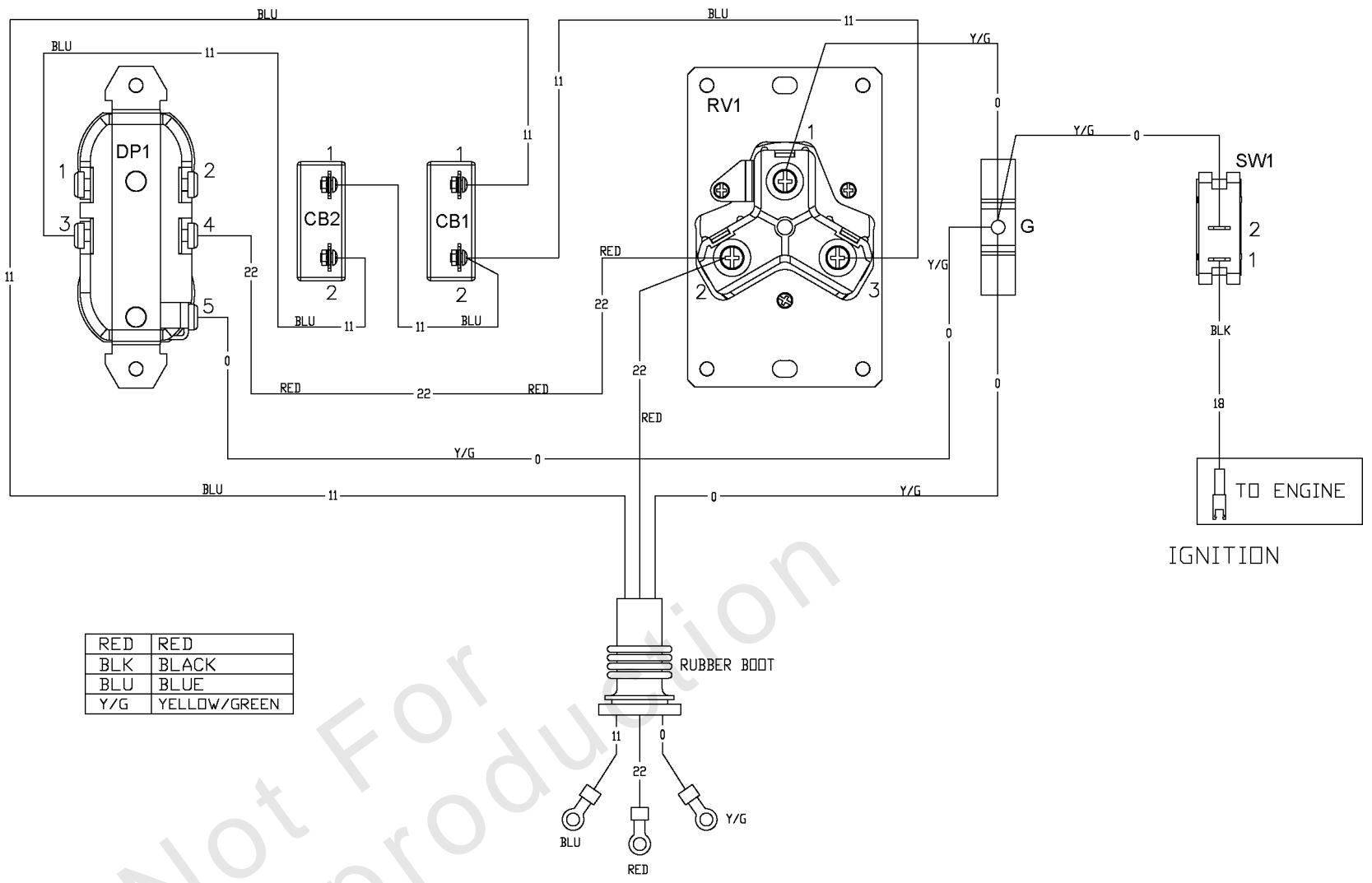

Not For Reproduction

Wiring Diagram (80017394WD)

REF NO	PART NO	QTY	DESCRIPTION
--	-----		Wiring Diagram Only
--	-----		WARNING - Generator Voltage Could Cause Electrical Shock or Burn Resulting in Death Or Serious Injury. To Avoid Electrical Shock Or Burn Hazard, Please Refer Service To Qualified Personnel.

Not For Reproduction

Wiring Schematic (80017394WS)

Note: Unless noted otherwise, use the standard torque specifications

Mfg. No: 030676-00

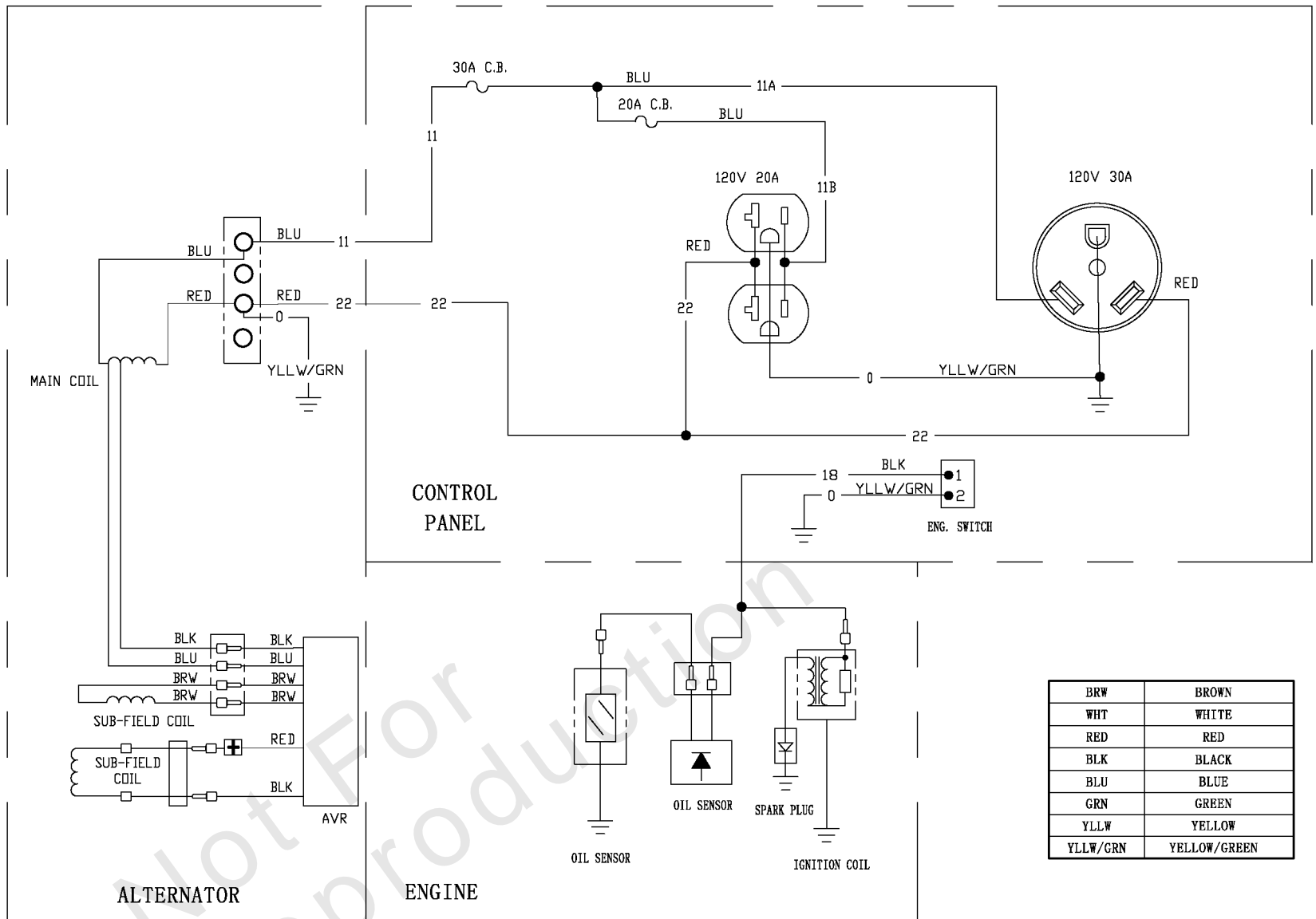

Wiring Schematic (80017394WS)

REF NO	PART NO	QTY	DESCRIPTION
--	-----		Wiring Schematic Only
--	-----		WARNING - Generator Voltage Could Cause Electrical Shock or Burn Resulting in Death Or Serious Injury. To Avoid Electrical Shock Or Burn Hazard, Please Refer Service To Qualified Personnel.

Not For Reproduction

Hardware Identification & Torque Specifications

Torque Specification Chart								
FOR STANDARD METRIC MACHINE HARDWARE (Tolerance ± 20%)								
Property Class	5.6		8.8		10.9		12.9	
	Class 5.6		Class 8.8		Class 10.9		Class 12.9	
Size Of Hardware	in/lbs	Nm.	in/lbs	Nm.	in/lbs	Nm.	in/lbs	Nm.
	ft/lbs		ft/lbs		ft/lbs		ft/lbs	
M3	5.88	.56	13.44	1.28	19.2	1.80	22.92	2.15
M4	13.44	1.28	30.72	2.90	43.44	4.10	52.56	4.95
M5	26.4	2.50	60.96	5.75	5.97	8.10	7.15	9.7
M6	44.64	4.3	7.3	9.9	10.3	14	12.1	16.5
M7	5.2	7.1	12.1	16.5	16.9	23	19.9	27
M8	7.7	10.5	17.7	24	25	34	29	40
M10	15	21	35	48	50	67	59	81
M12	26	36	61	83	86.2	117	103	140
M14	42	58	101	132	136	185	162	220
M16	64	88	147	200	210	285	250	340
M18	89	121	202	275	287	390	346	470
M20	126	171	290	390	405	550	486	660
M22	169	230	390	530	559	745	656	890
M24	217	295	497	375	708	960	840	1140
M27	320	435	733	995	1032	1400	1239	1680
M30	435	590	995	1350	1401	1900	1681	2280
M33	590	800	1349	1830	1902	2580	2278	3090
M36	759	1030	1740	2360	2441	3310	2935	3980
M39	988	1340	2249	3050	3163	4290	3798	5150

Torque Specification Chart						
FOR STANDARD MACHINE HARDWARE (Tolerance ± 20%)						
Hardware Grade	No Marks		SAE Grade 5		SAE Grade 8	
	SAE Grade 2		SAE Grade 5		SAE Grade 8	
Size Of Hardware	in/lbs	Nm.	in/lbs	Nm.	in/lbs	Nm.
	ft/lbs		ft/lbs		ft/lbs	
8-32	19	2.1	30	3.4	41	4.6
8-36	20	2.3	31	3.5	43	4.9
10-24	27	3.1	43	4.9	60	6.8
10-32	31	3.5	49	5.5	68	7.7
1/4-20	66	7.6	8	10.9	12	16.3
1/4-28	76	8.6	10	13.6	14	19.0
5/16-18	11	15.0	17	23.1	25	34.0
5/16-24	12	16.3	19	25.8	29	34.0
3/8-16	20	27.2	30	40.8	45	61.2
3/8-24	23	31.3	35	47.6	50	68.0
7/16-14	30	40.8	50	68.0	70	95.2
7/16-20	35	47.6	55	74.8	80	108.8
1/2-13	50	68.0	75	102.0	110	149.6
1/2-20	55	74.8	90	122.4	120	163.2
9/16-12	65	88.4	110	149.6	150	204.0
9/16-18	75	102.0	120	163.2	170	231.2
5/8-11	90	122.4	150	204.0	220	299.2
5/8-18	100	136	180	244.8	240	326.4
3/4-10	160	217.6	260	353.6	386	525.0
3/4-16	180	244.8	300	408.0	420	571.2
7/8-9	140	190.4	400	544.0	600	816.0
7/8-14	155	210.8	440	598.4	660	897.6
1-8	220	299.2	580	788.8	900	1,244.0
1-12	240	326.4	640	870.4	1,000	1,360.0

The guides and ruler furnished below are designed to help you select the appropriate hardware.



Nut, M8

Thread Diameter (mm)

Inside Diameter (in) Threads per inch

Nut, 1/2-16



Screw, M8- 1.25 x 25

Thread Diameter (mm) Distance between threads (mm) Body Length (mm)

Body Diameter Threads per inch Body Length (in)

Screw, 1/2- 16 x 2



Standard Hardware Sizing

When a washer or nut is identified as 1/2" (M8), this is the *Nominal size*, meaning the *inside diameter* is 1/2 inch (8mm metric thread diameter); if a second number is present it represents the *threads per inch* (distance between threads).

When bolt or capscrew is identified as 1/2 - 16 x 2" (M8 - 1.25 x 50), this means the *Nominal size*, or body diameter is 1/2 inch (8mm metric thread diameter), the second number, 16, represents the *threads per inch*, (*distance between threads*). The final number is the body length of the bolt or screw, 2 inches (50mm).

NOTES

- These torque values are to be used for all hardware excluding: locknuts, self-tapping screws, thread forming screws, sheet metal screws and socket head setscrews.
- Recommended seating torque values for locknuts:
 - for prevailing torque locknuts - use 65% of grade 5 torques.
 - for flange whizlock nuts and screws - use 135% of grade 5 torques.
- Unless otherwise noted on assembly drawings, all torque values must meet this specification.

Common Hardware Types

Hex Head Capscrew



Washer



Carriage Bolt



Hex Nut

Wrench & Fastener Size Guide

1/4" Bolt or Nut Wrench—7/16"	5/16" Bolt or Nut Wrench—1/2"	3/8" Bolt or Nut Wrench—9/16"	7/16" Bolt or Nut Wrench (Bolt)—5/8" Wrench (Nut)—11/16"	1/2" Bolt or Nut Wrench—3/4"
M6 Bolt or Nut Wrench—10mm	M8 Bolt or Nut Wrench—13mm	M10 Bolt or Nut Wrench—17mm	M12 Bolt or Nut Wrench—19mm	M14 Bolt or Nut Wrench—22mm

